

ENVIRONMENT

Cars should impose as close to zero burden on the environment as possible during their lifetimes.

Permanently Engaged Starter

OVERVIEW

The Permanently Engaged Starter improves fuel economy and the vehicle's Stop-Start performance.

CONFIGURATION

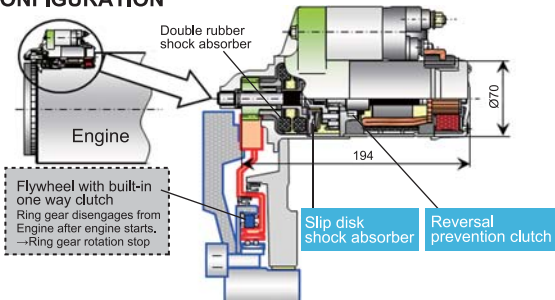

SUMMARY

Engine: 2.0L, Gasoline Transmission: 5 speeds manual

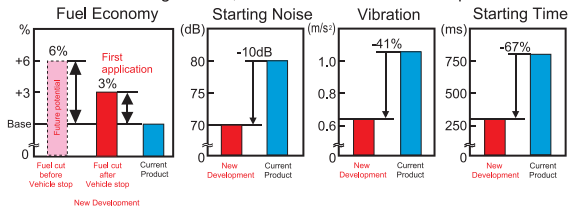

FEATURES

- Potential to expand fuel cut area due to capability to restart at anytime.
- Starting noise reduction by the double rubber shock absorber.
- Vibration level reduction by the reversal prevention clutch and the double rubber shock absorber.